



Informationsvortrag bei der PR-Lounge in Köln / Wahn

Operative Information

Oberst Horst Schallenberg

Stellvertretender Kommandeur ZOpInfo,

Mayen

26. Juni 2007



Gliederung

1. Was ist Operative Information?
2. Aufträge und Kernfähigkeiten
3. Organisation
4. Einsätze
5. Reservisten



Gliederung

1. Was ist Operative Information?
2. Aufträge und Kernfähigkeiten
3. Organisation
4. Einsätze
5. Reservisten



Höchste militärische Kunst

*„Höchste militärische Kunst besteht im Brechen des feindlichen Widerstandes
ohne Kampf.“*

Die Kunst des Krieges, Kap. III, Nr. 3

Sun Tzu (Chinesischer Philosoph und General, 500 v.C.)



Definition

Operative Information

wirkt mit kommunikativen Mitteln und Methoden auf Zielgruppen im Einsatzgebiet ein, um

- deren Einstellungen und Verhalten zu beeinflussen,
- Vertrauen und Unterstützung für den eigenen Auftrag zu erzielen und damit
- zum Schutz eigener Kräfte beizutragen.



Kommunikative Mittel u. Methoden

- Hörfunk
- TV- / Videobeiträge
- Druckerzeugnisse
- Lautsprecheraufrufe
- Direktkommunikation (face-to-face)
- Internet
- sonstige wirksame Mittel



Zielgruppen



Zielgruppen werden durch die

politische Leitung

festgelegt

und

durch das

Bundesministerium der Verteidigung

befohlen.



Zielgruppen



Nicht-verbündete
Streitkräfte



Zielgruppen



Konfliktparteien



Zielgruppen



Bevölkerungsteile
fremder oder
gegnerischer Staaten



Zielgruppen



von Katastrophen
betroffene
Bevölkerungsteile



Keine Zielgruppen

Keine Zielgruppen sind:

eigene oder verbündete Streitkräfte

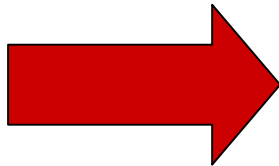

die eigene Bevölkerung

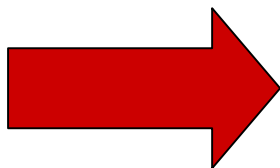



Einordnung im Informationsraum



eigene/neutrale
Bevölkerung



eigene
Soldaten

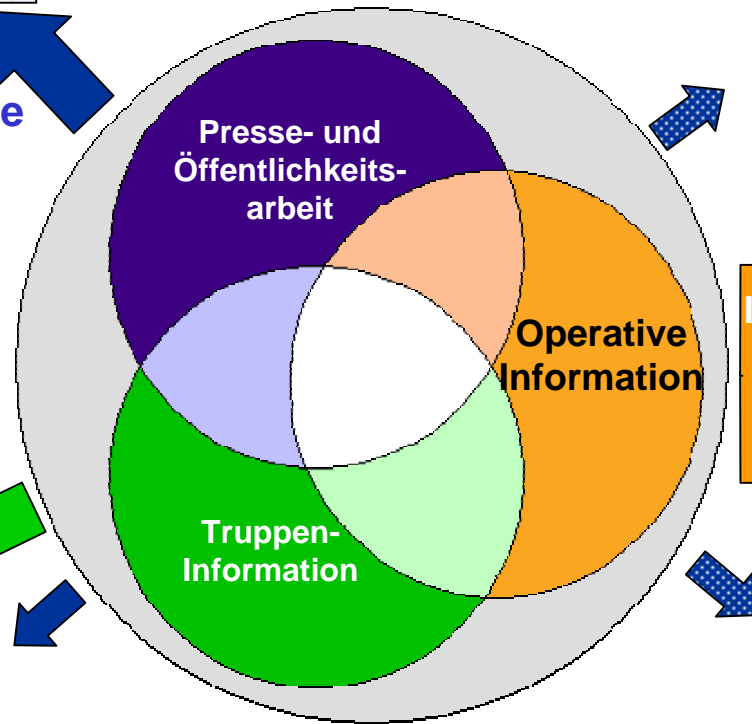

Einsatzraum

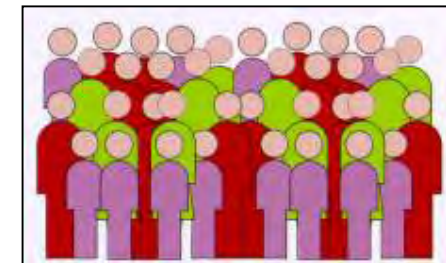

Bevölkerung
Im Einsatzraum

Information
+
Argumen-
tation



Gegnerische Streitkräfte/
Konfliktparteien



Gliederung

1. Was ist Operative Information?
- 2. Aufträge und Kernfähigkeiten**
3. Organisation
4. Einsätze
5. Reservisten



Aufträge der OpInfo-Truppe

(1)

- Einwirken auf Zielgruppen mit **Kommunikation**
- **Interkulturelle Einsatzberatung**
- **Beteiligung an Eingreifoperationen**
- **Unterstützung von Einsätzen aus der Heimat**
- **Beratung BMVg / KdoBeh / Stäbe / TrFhr**
- **Weiterentwicklung der OpInfoTr**
- **Lehre und Ausbildung („Truppenschule“)**



Aufträge der OpInfo-Truppe

(2)



- **Truppenbetreuung**
mit Hörfunk und Feldpostkarten



- **Einsatzdokumentation**
für die pol. / mil. Leitung / Führung
mit Einsatzkameratrupps (EKT)



Kernfähigkeiten

- Interkulturelle Handlungskompetenz
- Bewertung der soziokulturellen Lage von Zielgruppen als Teil des Führungsprozesses
- Entwicklung von verhaltenswirksamen Informations- und Argumentationslinien und deren zielgruppenorientierte, mediale Umsetzung
- Einwirken auf Zielgruppen mit eigenen Massenkommunikationsmitteln
- Wirkungsanalyse



Gliederung

1. Was ist Operative Information?
2. Aufträge und Kernfähigkeiten
- 3. Organisation**
4. Einsätze
5. Reservisten



Organisation der OpInfoBw

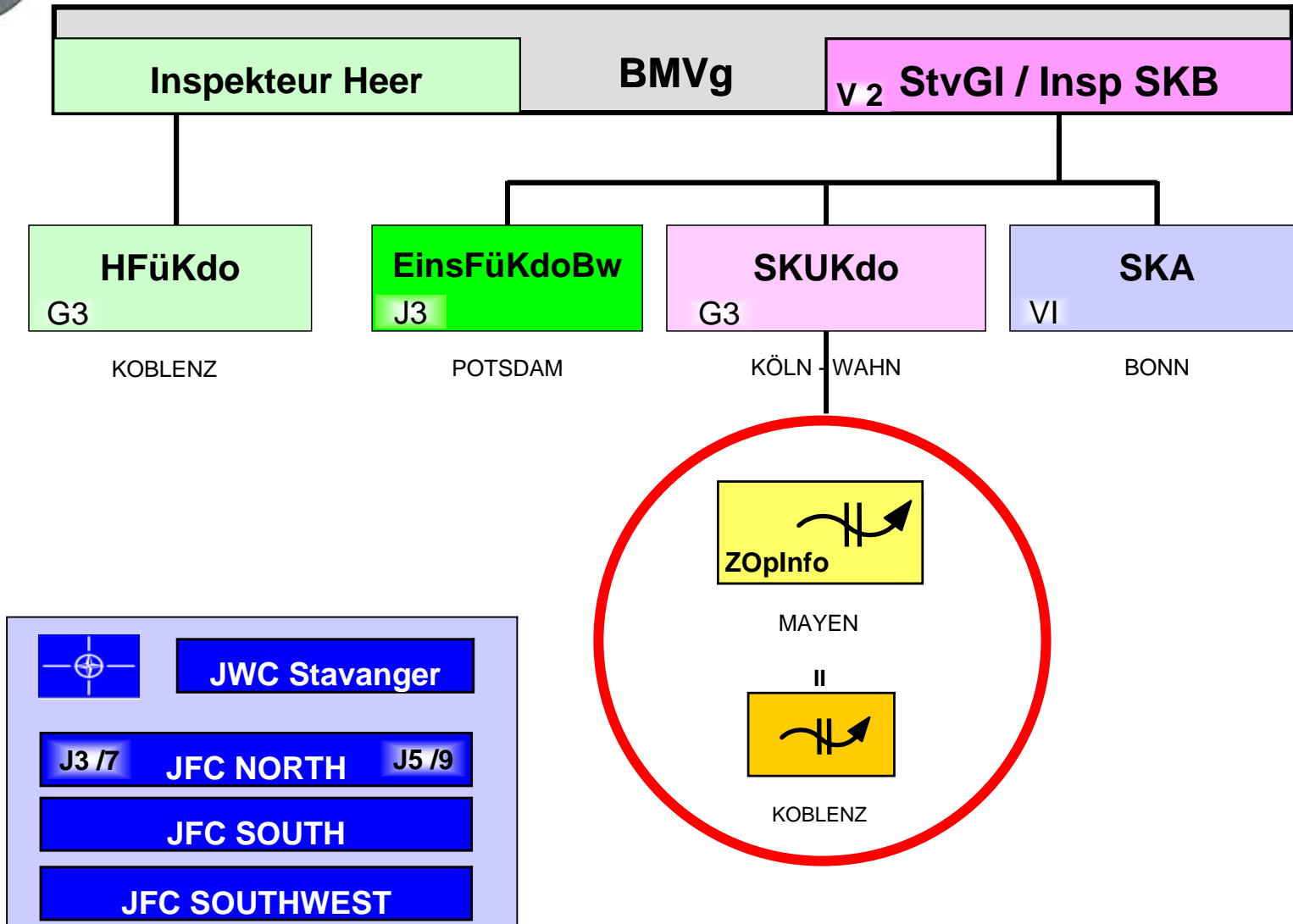



Dislozierung OplInfoTr

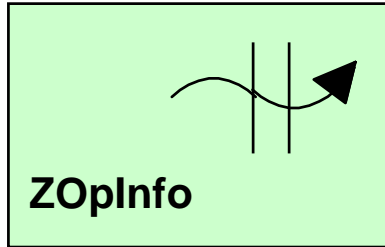

•••
Stationäre
Druckerei



ADENAU

KOBLENZ

MAYEN

950

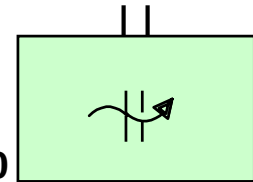

Mosel

Rhein

Rheinland-Pfalz





Gliederung der OplInfoTr

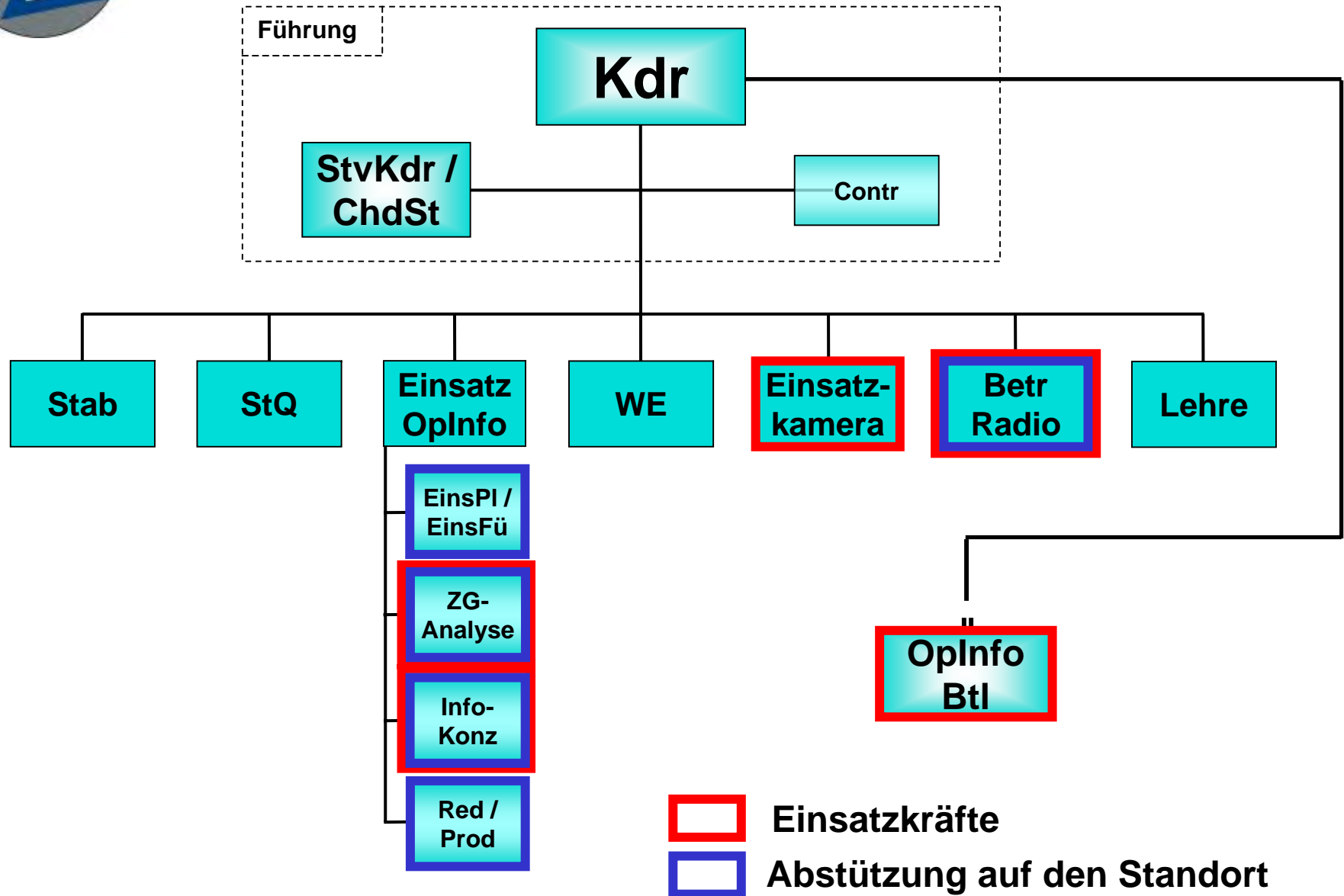



Dezernat Einsatzkamera

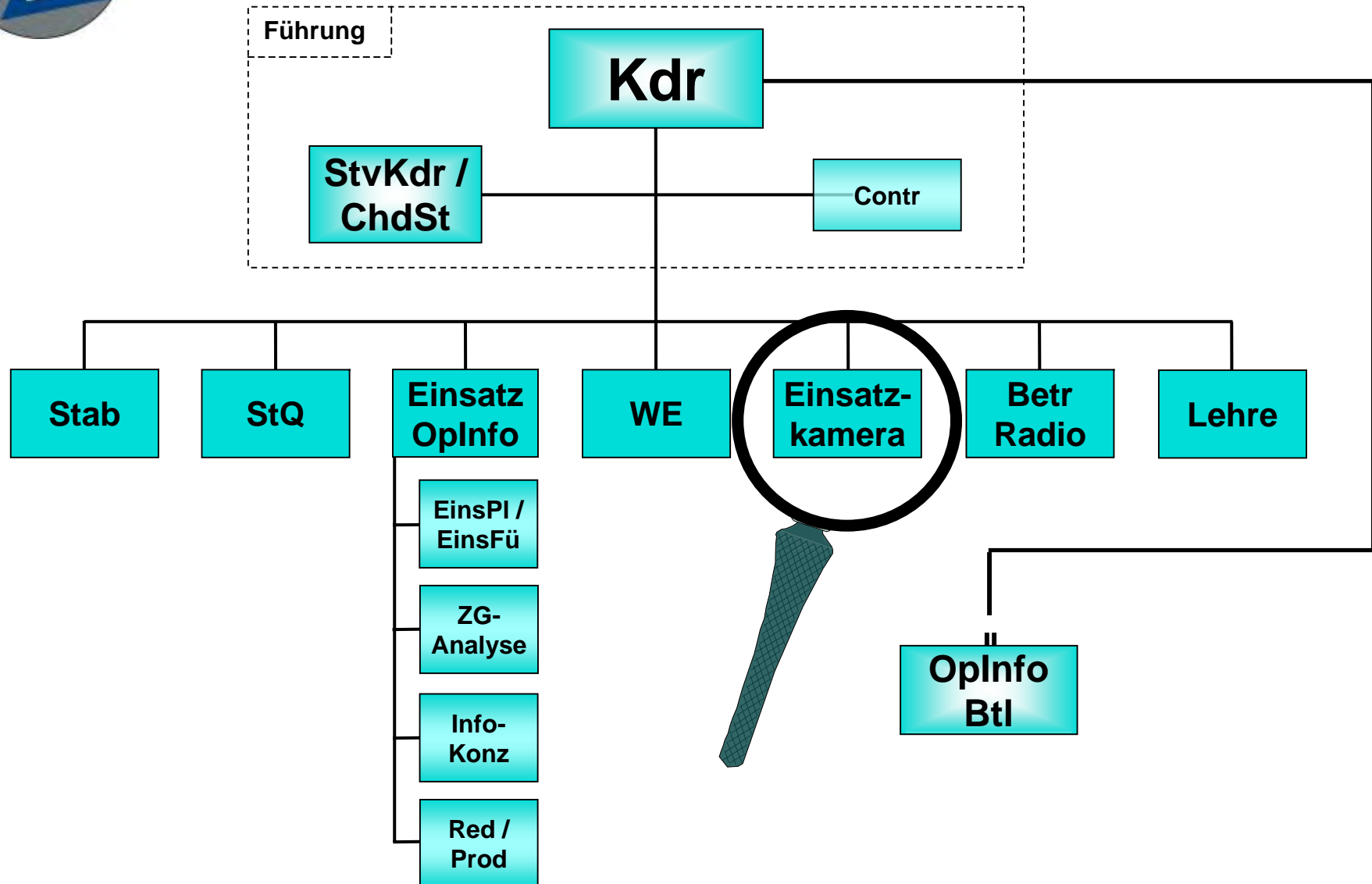



Auftrag Einsatzkamera



**Einsatzkamera dokumentiert
und informiert mit Video und Foto:**



- **vor und während eines Einsatzes für die Lagefeststellung und Entscheidungsvorbereitung der politischen Leitung und militärischen Führung,**
- **zur Unterstützung der Einsatznachbereitung und -auswertung sowie**
- **zur Nachweissicherung und Schadenserfassung.**



Der Einsatzkameratrupp



... besteht aus fünf Soldaten.

Derzeit stehen fünf Trupps für den Einsatz bereit.

Sieben Trupps sollen aufgestellt werden.

Redakteuroffizier

Leiter

2 Kameraleute / Cutter

**Satelliten-
kommunikations-
techniker**





Beitragsübermittlung

Empfangsantenne
in GEROLSTEIN

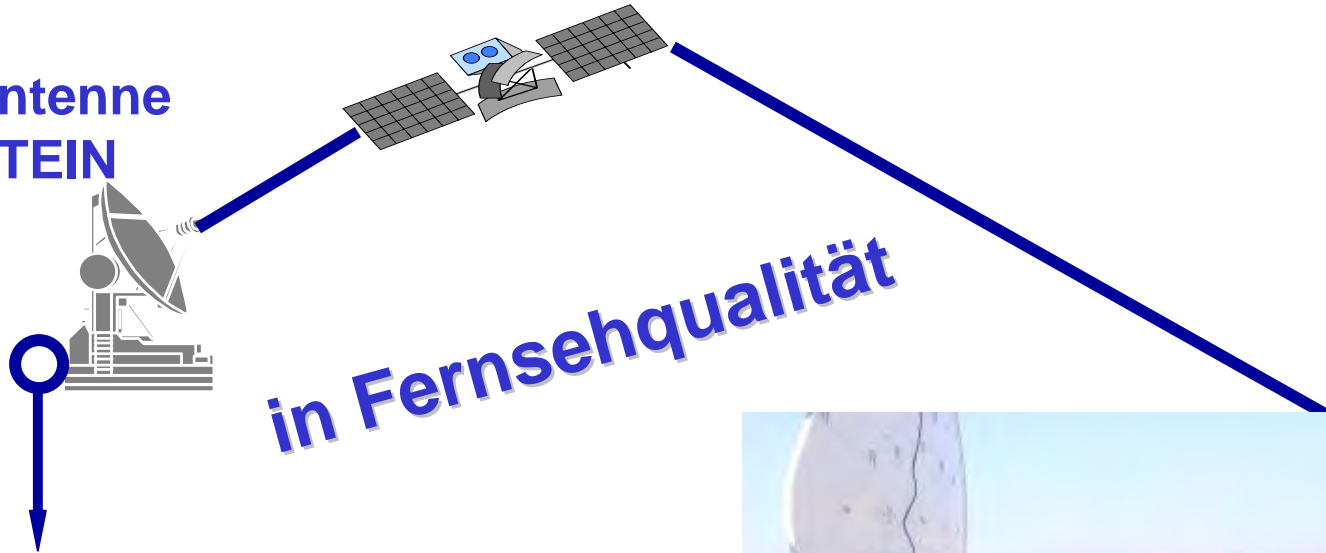

Lagezentrum
• BMVg
• EinsFüKdoBw

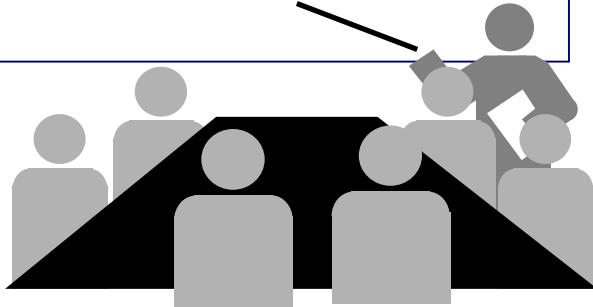

Sendeantenne im Einsatzgebiet



Dezernat Betreuungsradio

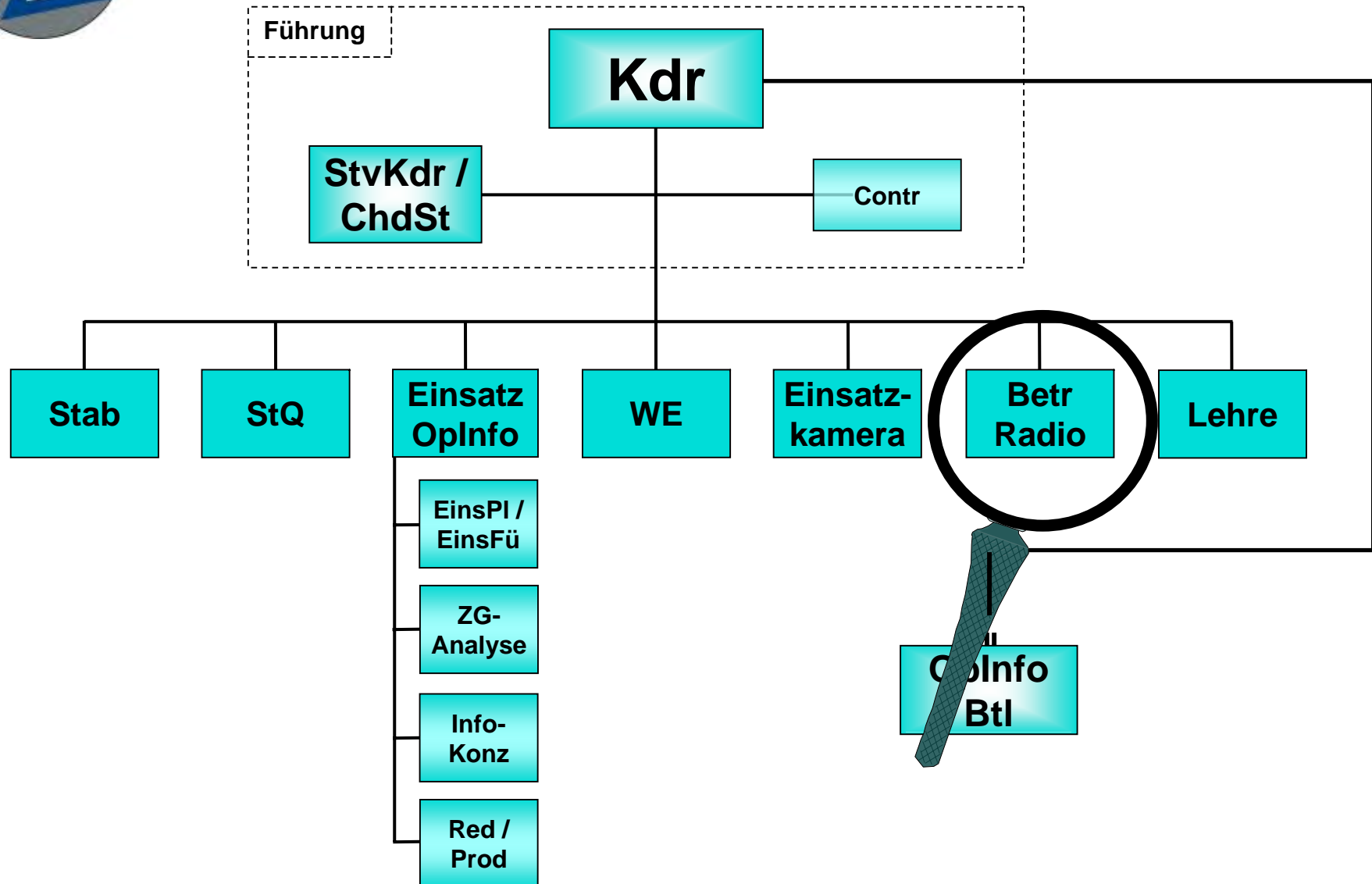



Dezernat Betreuungsradio



**Der Truppenbetreuungssender der
Bundeswehr im Ausland**

(seit 1974)



Auftrag Betreuungsradio

RADIO ANDERNACH

- produziert und sendet Radioprogramme für deutsche Soldaten im Einsatz,
- unterstützt die Einsatzredaktionen mit Programmanteilen aus Deutschland,
- baut auf und betreibt bewegliche Sendeanlagen,
- produziert Tonträger für deutsche Soldaten im Ausland.



Abteilung Einsatz

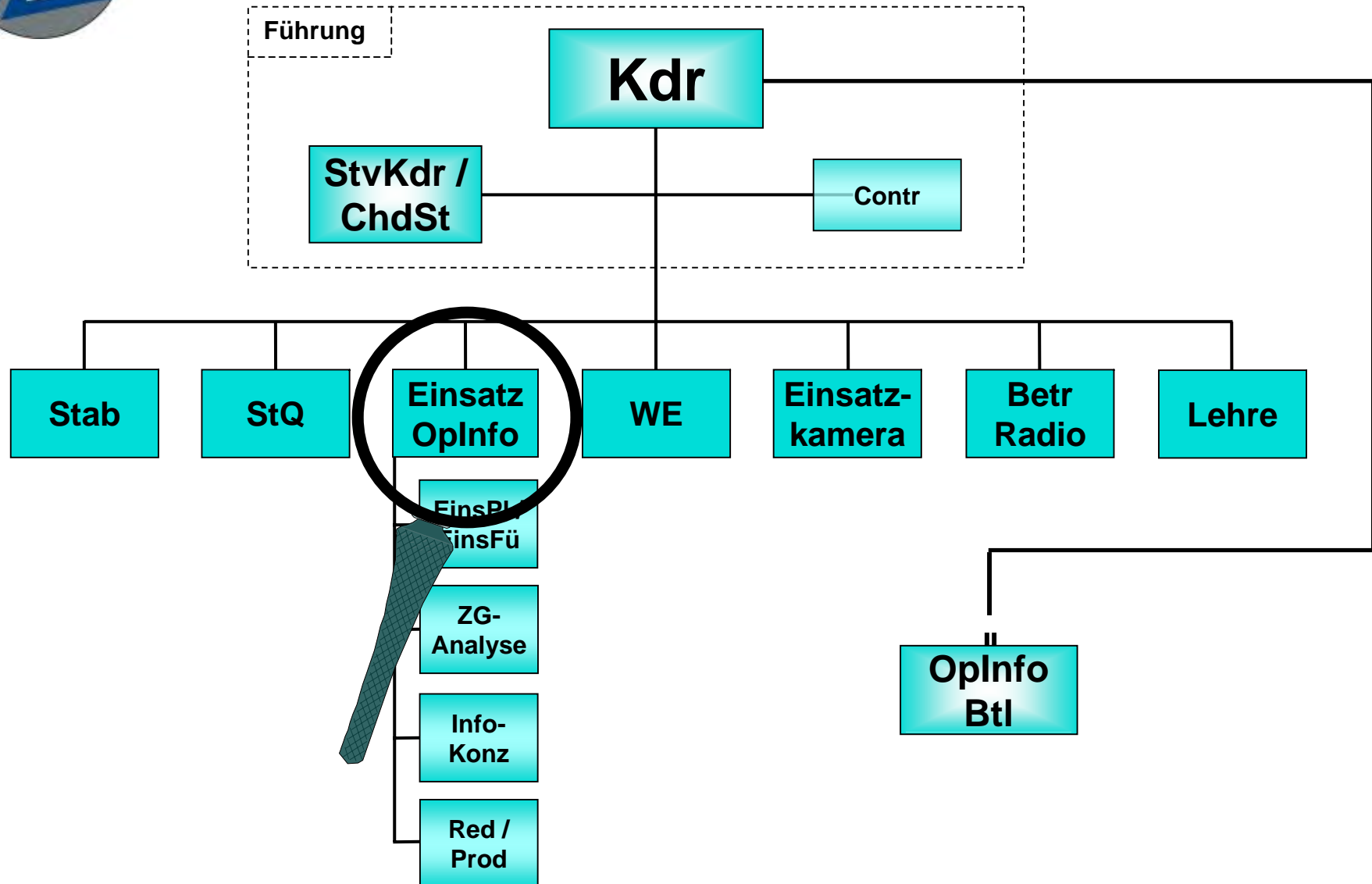



Auftrag Abteilung Einsatz

- Fachliche Zuarbeit zur **Einsatzplanung** von OplInfoKr (BMVg - Fü S V 2 / EinsFüKdoBw)
- Beobachten und **Auswerten der Kommunikationslage, der inneren Situation und äußerer Merkmale** zugewiesener Zielgruppen
- Erarbeiten allgemeiner und spezieller **Informationskonzepte** auf wissenschaftlicher Basis für den Einsatz von OplInfoKr
- Unterstützen eingesetzter OplInfo-Kontingente mit **Programmanteilen für alle Medien (AStO)**
- Dokumentieren und **Archivieren**, zentral für die OplInfoTr
- **Führen der Lage** der eingesetzten OplInfoKr



OpInfo-Bataillon

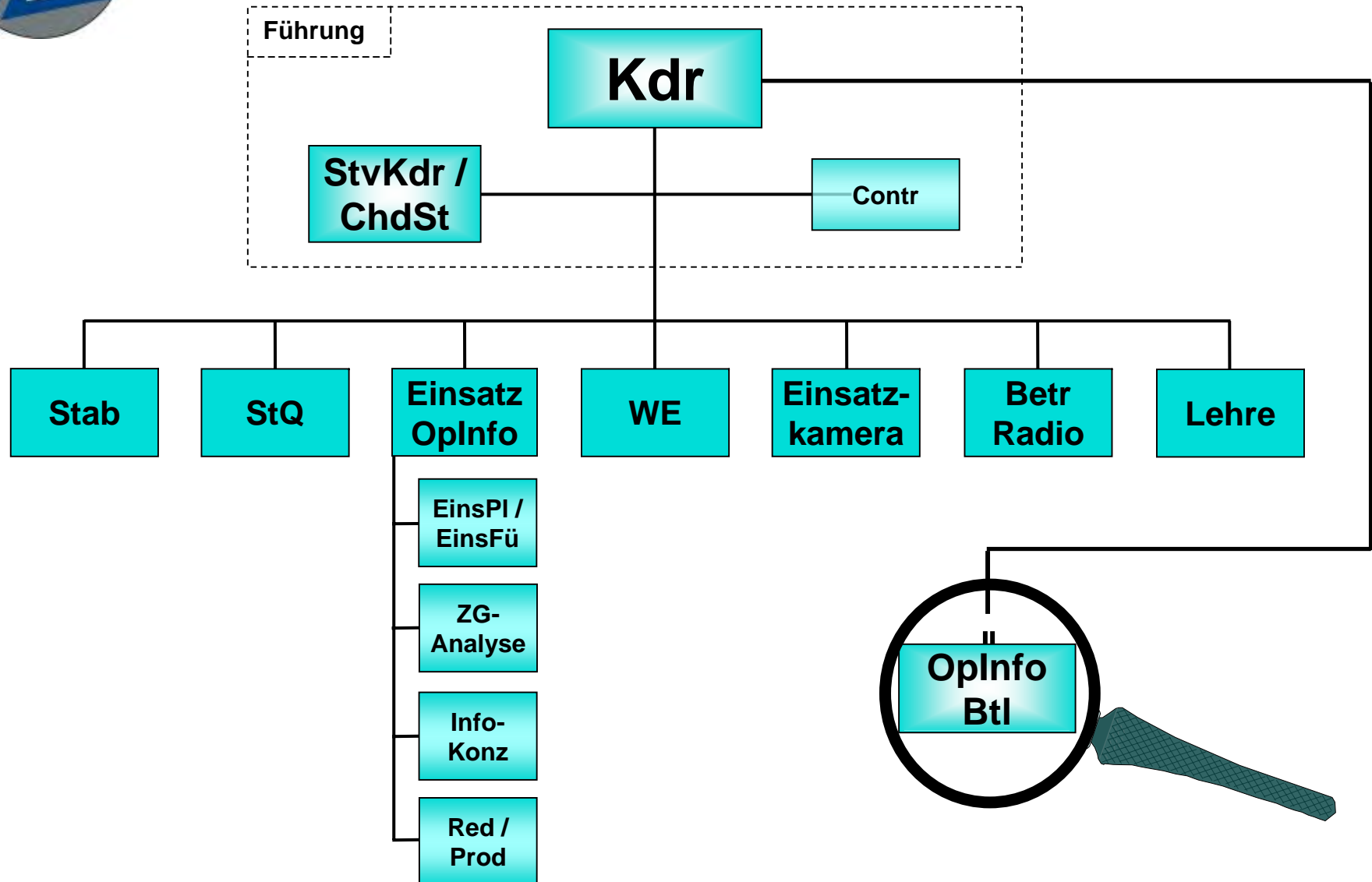



OpInfo-Bataillon

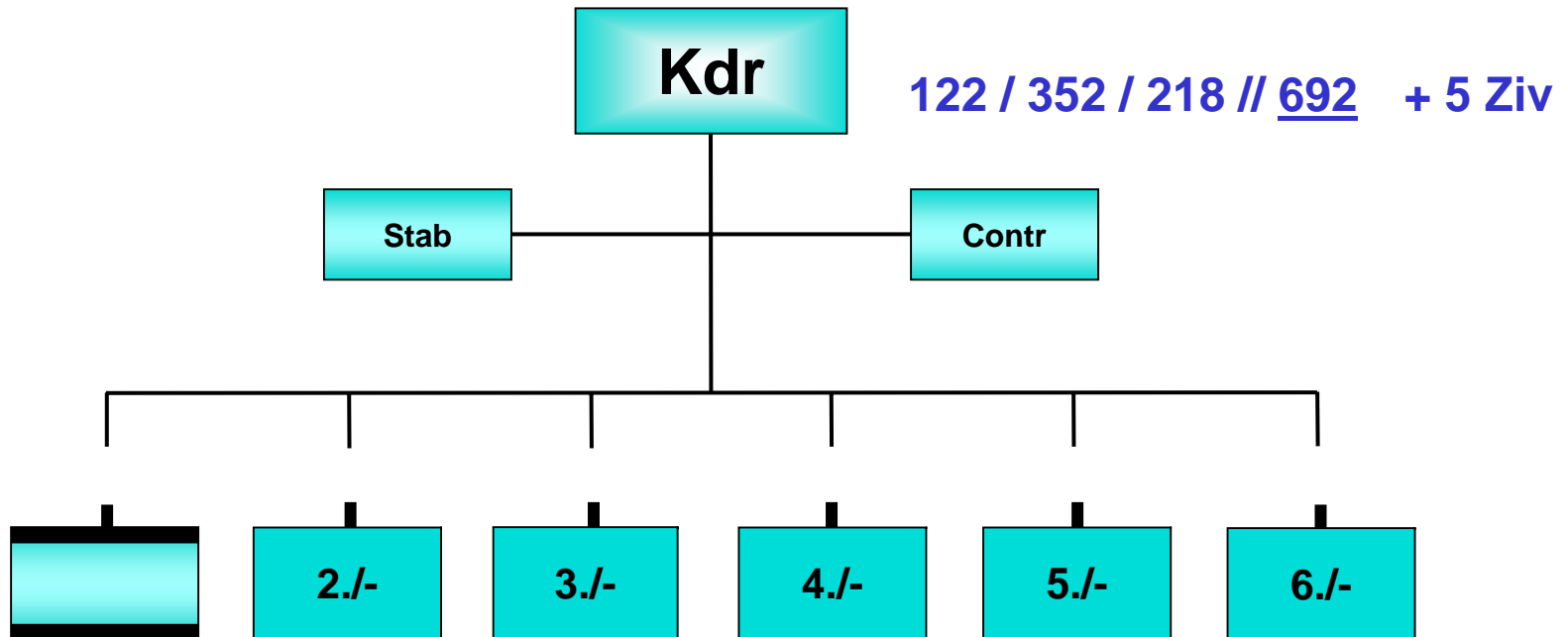



Gliederung

1. Was ist Operative Information?
2. Aufträge und Kernfähigkeiten
3. Organisation
- 4. Einsätze**
5. Reservisten



Richtlinien für den Einsatz

Ministeriell abgestimmte **Richtlinien für den Einsatz** geben vor:

- Zielgruppen
- Grundsätzlich durchzuführende OpInfo-Maßnahmen
- Informationsziele und Tabu-Themen
- Unterstellungsregelungen
- Verfahren für die Freigabe von OpInfo-Produkten

Quelle: TK OpInfoBw



Produktbeispiele



Afghanistan





„Prozessorganisation“ OpInfo





Zielgruppenanalyse



Pre- und Post-Tests

Fokusgruppen

Umfragen

Media Monitoring

Wirkungsanalysen



Zielgruppenradio

Radio Sada-e-Azadi (Kabul) Radio Sada-e-Azadi Shamal (AOO RC North)

- In Dari und Pashto
- Empfang in KABUL und im AOO RC North
- 24 Std Programm an 7 Tagen/Wo
- Prime - Time zwischen 06:00 und 09:00 Uhr sowie 15:00 und 21:00 Uhr





Beilagen in lokalen Zeitungen

“I am glad to meet you in Herat.”
“I am glad to meet you in Herat.”

Salaam alaikum honourable people in Herat!

I am Sergeant Major Giuseppe Constantino and I am 32 years old. My hometown is Naples, a beautiful city on the Italian seaside.

My colleagues and I are in Herat invited by your government to assist and support you in the reconstruction of your country. The ISAF Provincial Reconstruction Team is the contribution of my country and it is people to help you.

Before I was sent to Afghanistan I informed myself about your country, the people and its history. I learned that the Afghan people are famous for their will to change their situation and for their hospitality.

I am proud to serve in your country. I am glad to meet you in Herat. Take our helping hand and co-operate with us Italians and other nations. Beside you, we will accompany you on your way ahead in a bright and prosperous Afghanistan.

“I am Captain Perez Costales”
“I am Captain Perez Costales”

Salaam alaikum honourable people in Qal-e Naw and Badghis Province!

I am Captain Perez Costales and I am 37 years old. My hometown is Pamplona a beautiful city in Spain.

Before I was sent to Afghanistan I informed myself about your country and its history. I learned that the Afghan people are famous for their will to change their situation and for their hospitality.

We come to your country invited by your government to collaborate in increasing the safety and the security in the Badghis province.

We ensure the crucial security conditions and stability. Together with the Afghan government, international and national organisations and of course with your help we will start the reconstruction of the province and the improvement of your living conditions.

We need some time to establish our Provincial Reconstruction Team (PRT). After a short period you will step by step the results of our presence – a presence what is a benefit the all residents of Badghis province.



Weitere Print-Produkte





Taktische OpInfo-Gruppe



- Einzelne Lautsprecher - Aufrufe
- Lautsprecher-Programme
- Direktkommunikation; RFI
- 2 zusätzliche tragbare Lautsprecherausrüstungen (ManPack)
- 1 LtsprSoldat und 1 Übersetzer
- 2000m (400m) maximale Reichweite





TV



- Spots
- Reportagen
- Nachrichtensendungen
- Sendezeit wird angemietet
- Landesweite Ausstrahlung





www.sada-e-azadi.net

- 40 – 50 Internetcafés in Kabul
- 1 - 3 USD / Std
- Nutzer: überwiegend gehobene soziale Schicht sowie Entscheidungsträger

رادیو
صدای آزادی

به وب سایت صدای آزادی خوش آمدید
برای داخل شدن به صفحه، سمبول آیساف را کلیک نمایید.

Kunduz FM 89,5 MHz د آزادي غږ وېب سایټ ته بڼه راغلاست.
پاڼی ته دننوتو پخاطر د آیساف سمبول کلیک کړي.

Kabul FM 88,5 MHz

This Website is intended for the people of Afghanistan and is an authorized ISAF product, approved by Commander ISAF.



Gliederung

1. Was ist Operative Information?
2. Aufträge und Kernfähigkeiten
3. Organisation
4. Einsätze
- 5. Reservisten**



Rolle des Reservisten bei OpInfo



F2F Communication in Mazar-e Sharif



Audienz bei König Mohammed Sahir Schah



Ende des Vortrags

پوښتني؟

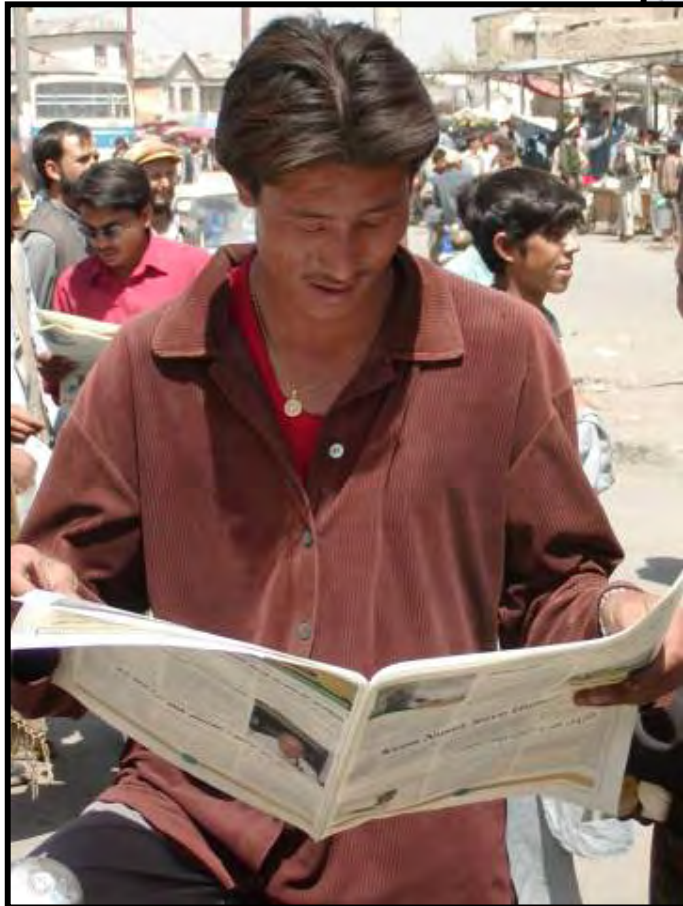

سوالات؟

